



Connect. Communicate. Collaborate

European NRENs & GÉANT2: Next Generation Network Advances in Hybrid Switching & IPv6 Routing

Vasilis Maglaris

maglaris@netmode.ntua.gr

Chairman, NREN Policy Committee - GÉANT Consortium
Professor, National Technical University of Athens – NTUA

ICCGI 2006

Bucharest, August 1 2006



NTUA – NATIONAL TECHNICAL
UNIVERSITY OF ATHENS



NRENs – GÉANT: A European Success Story



Connect. Communicate. Collaborate

Some factors

- Century old Telecom (+ 40 years from the ARPAnet to the Internet) experience: Proven *“Network Externalities”* → Sharing tradition
- Industry needs for *Next Generation Network* proofs of concept, synergy with R&E community → the ARPAnet paradigm from the US of America to the *“US of Europe”*
- *Foresight* of National + EU funding authorities
- A decade (+) of success in serving R&E needs of the Continent → Easing *“digital divides”* & involving powerful education communities: educators, students, pupils (*e-Schools* + *e-Public_Sector ?*)
- *Solidarity* – human networking of NREN community
- Stable *Governance*: NRENs, NREN PC + {Exec, DANTE, TERENA}
- Global outreach



NTUA – NATIONAL TECHNICAL
UNIVERSITY OF ATHENS



The NREN PC



Connect. Communicate. Collaborate

Austria (**ACOnet**)

Belgium (**BELNET**)

Bulgaria (**ISTF**)

Croatia (**CARNet**)

Czech Republic (**CESNET**)

Cyprus (**CYNET**)

Germany (**DFN**)

Estonia (**EENet**)

France (**RENATER**)

Greece (**GRNET**)

Hungary (**HUNGARNET**)

Ireland (**HEANet**)

Israel (**IUCC**)

Italy (**GARR**)

Latvia (**LATNET**)

Lithuania (**LITNET**)

Luxembourg (**RESTENA**)

Malta (**UoM**)

Netherlands (**SURFNET**)

Nordic Countries – Denmark, Finland, Iceland, Norway, Sweden (**NORDUNET**)

Poland (**PSNC**)

Portugal (**FCCN**)

Romania (**RoEduNet**)

Russia (**JSCC**)

Slovakia (**SANET**)

Slovenia (**ARNES**)

Spain (**RedIRIS**)

Switzerland (**SWITCH**)

Turkey (**ULAKBIM**)

United Kingdom (**UKERNA**)

PLUS NON-VOTING MEMBERS:

Delivery of Advanced Network Technologies to Europe Ltd. (**DANTE**)

Trans-European Research & Education Networking Association (**TERENA**)

PERMANENT OBSERVERS: **CERN**, **AMREJ**, **MARNET**

GÉANT2 Global Connectivity October 2005

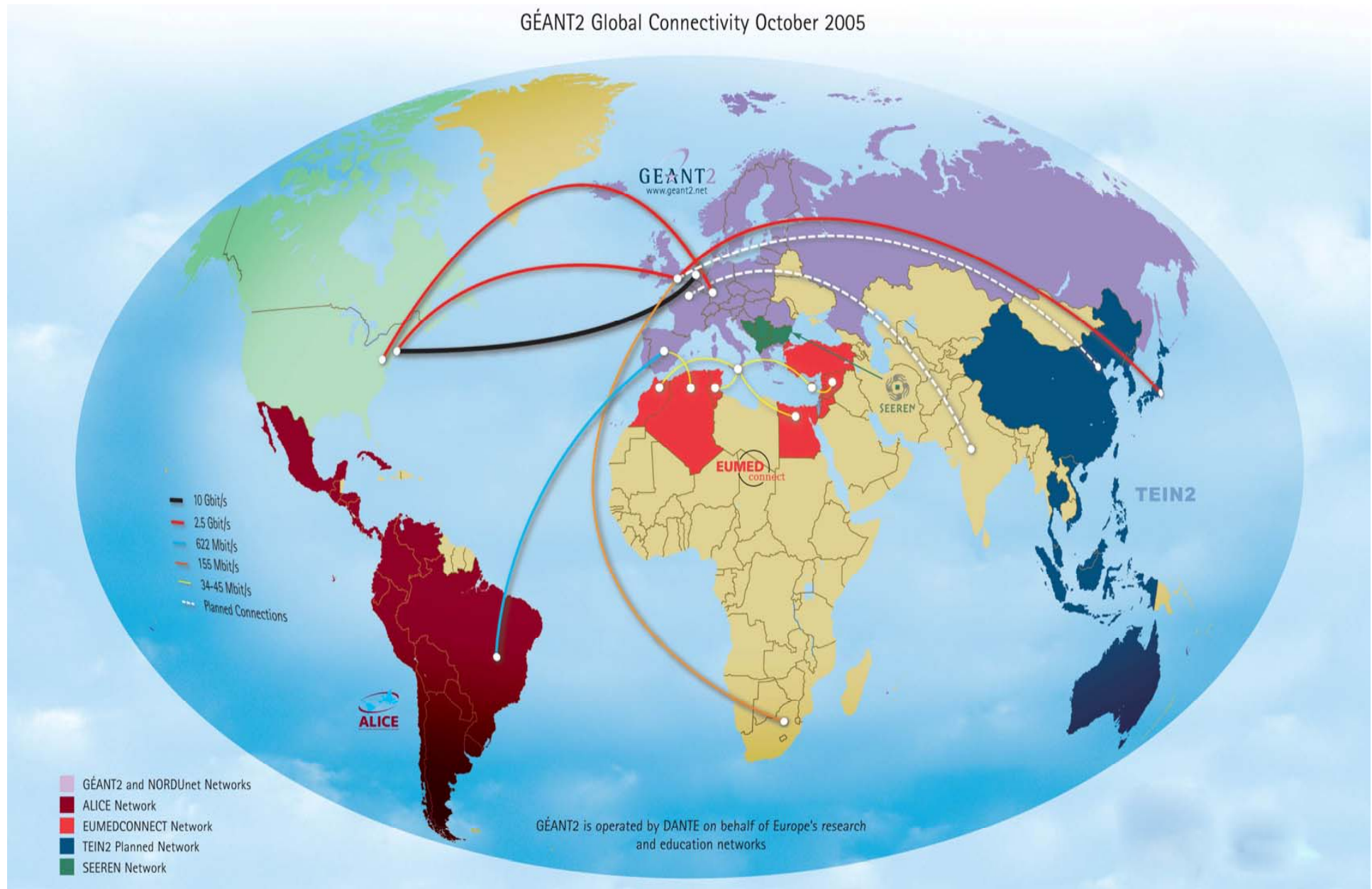

e-IRG Recommendation on Hybrid Networking & GÉANT



Connect. Communicate. Collaborate

“The e-IRG stresses the importance of flexibly configurable, reliable end-to-end optical provision to European researchers and e-Science projects. This service should co-exist with routed IP connectivity and follow the three tier hierarchical European paradigm: Campus LAN, NREN and Pan-European GÉANT network”

Den Haag, 19/11/2004



NTUA – NATIONAL TECHNICAL
UNIVERSITY OF ATHENS





Connect. Communicate. Collaborate

GÉANT2 Topology

15+ NRENs
interconnected
within the Dark
Fibre (DF) “cloud”

Rest, via leased
“lambda” and
SDH circuits

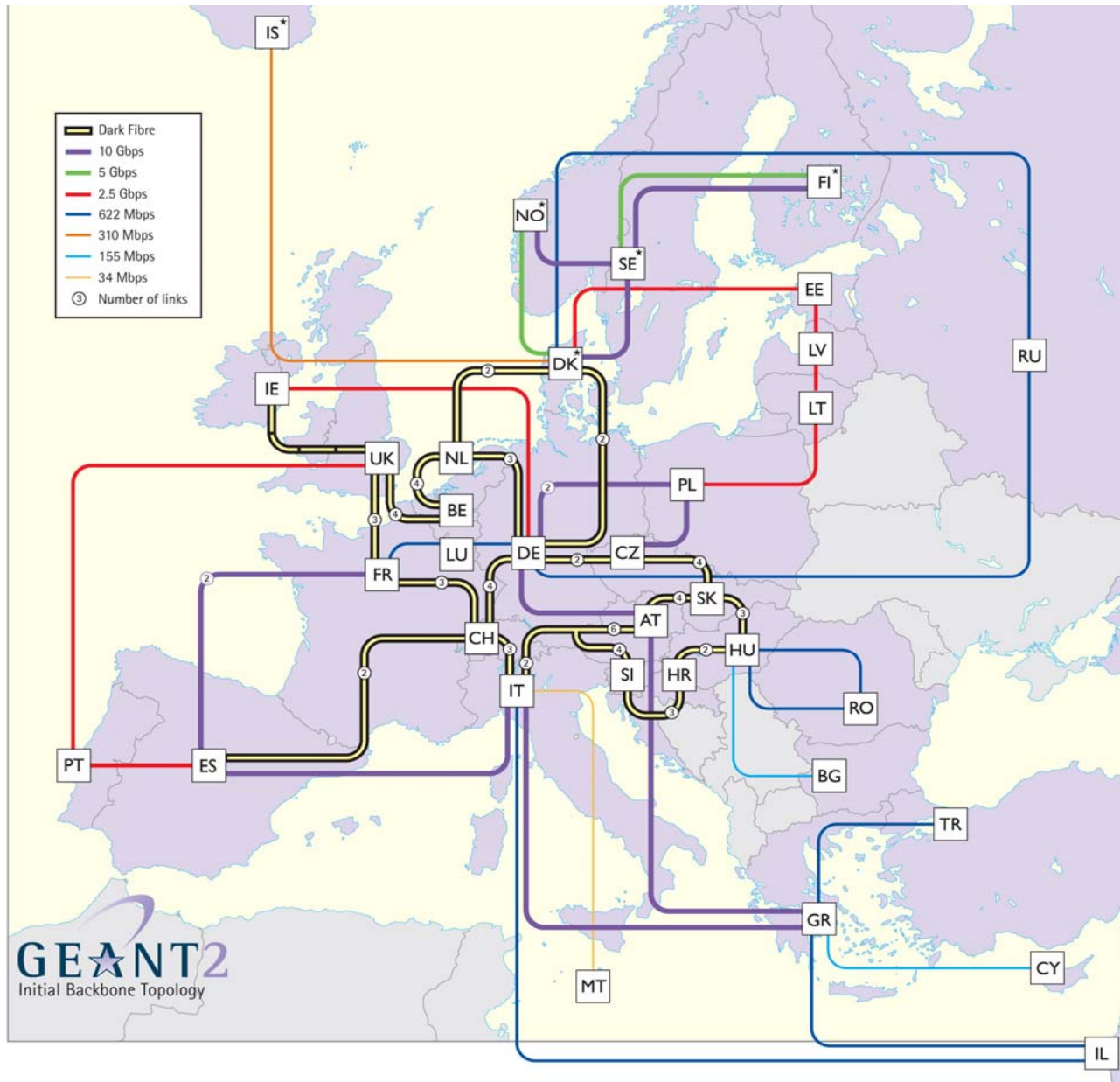

Provision of end-to-end (e2e) Services to e-Science Initiatives



Connect. Communicate. Collaborate

- Up to now: Packet Switched **IP** (Layer 3) & MPLS Managed Bandwidth Services – VPNs
- From now on the hybrid NREN - GÉANT2 service model also enables:
 - Layer 2 **Switched** e2e circuits (e.g. 1 GigE) involving GÉANT2 facilities (local circuits provided by NRENs & Campuses)
 - 10 Gig **Optical Private Networks (OPNs)** configured for large e-Science projects using GÉANT2 DWDM & NREN - Campus **lightpaths**
- **Pricing** of additional e2e lightpaths: Incremental costing of GÉANT2 Dark Fibre, charged to projects via hosting NRENs, **Global extensions** (if possible) under similar terms
- **Planning** based on common understanding and “accurate” prediction of requirements (bandwidth, availability, delay, jitter ...)
- Who, how and to what extent **provisions, manages, monitors, charges, absorbs the costs, undertakes risks** in a **multi-domain** network of HPC - GRID resources?

**{Large Hadron Collider - LHC Computing Grid T0 to T1, EGEE, DEISA, eVLBI}
+ {NRENs, GEANT2, DANTE}**

pave the way & uncover hidden issues (technical & managerial)

LHC TIER0 – TIER1 Optical Private Network - OPN, scenario based on work by *Roberto Sabatino* DANTE



Connect. Communicate. Collaborate

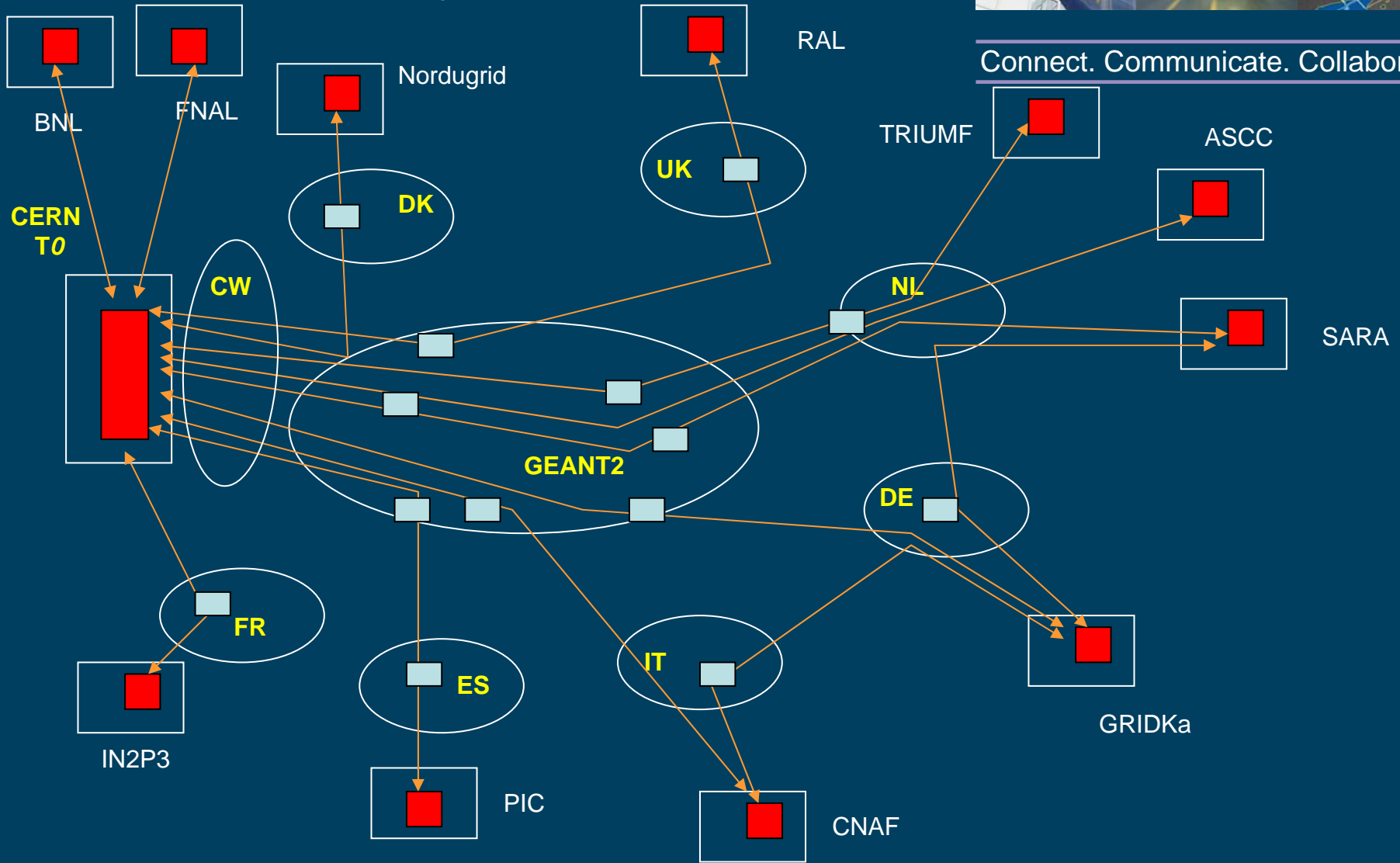

NTUA – NATIONAL TECHNICAL UNIVERSITY OF ATHENS



LHC Lightwave Assignment on GÉANT2 Backbone

Hans Döbbling, DANTE



Connect. Communicate. Collaborate

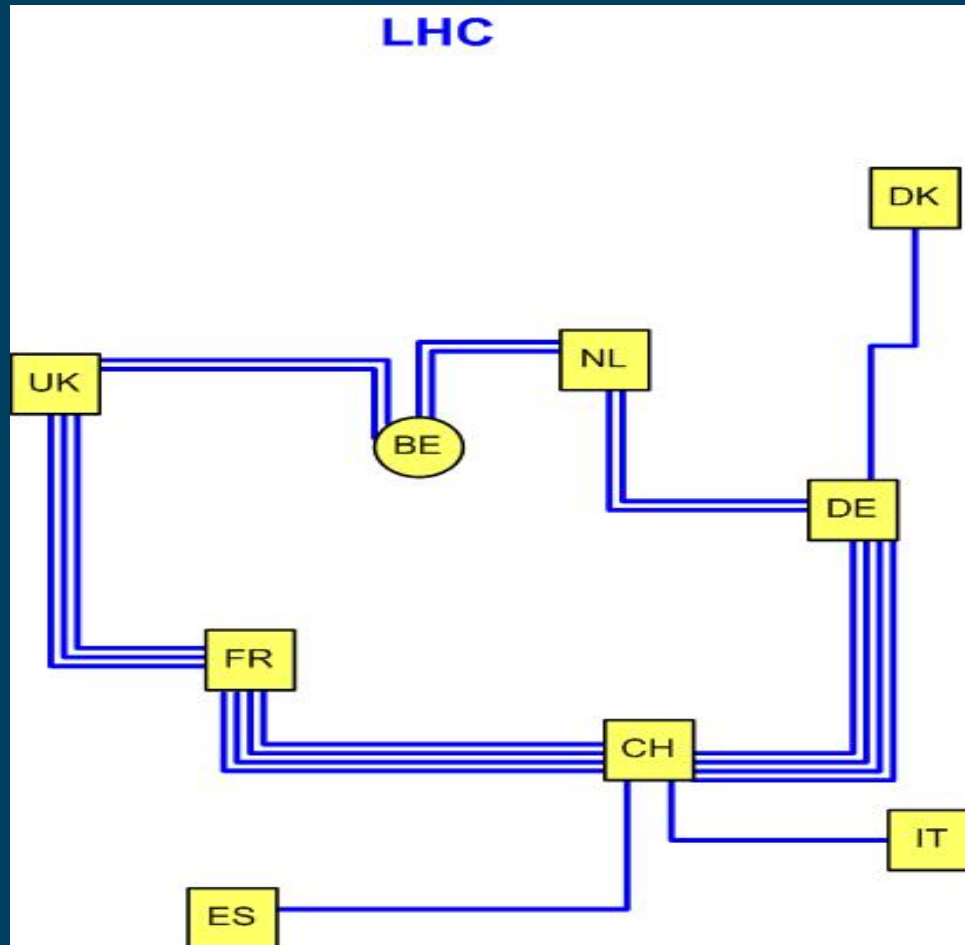

DEISA Lightwave Assignment on GÉANT2 Backbone

Hans Döbbling, DANTE



Connect. Communicate. Collaborate

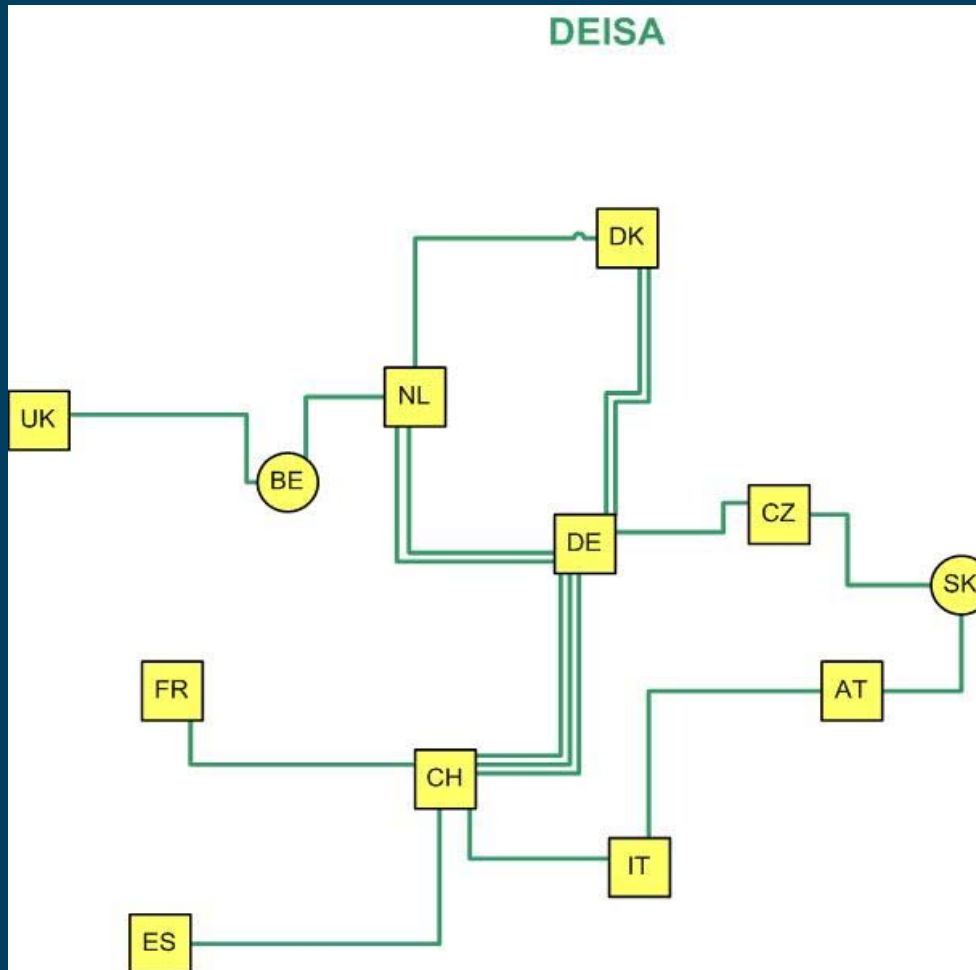

LHC + DEISA Lightwave Assignment on GÉANT2 Backbone

Hans Döbbling, DANTE



Connect. Communicate. Collaborate

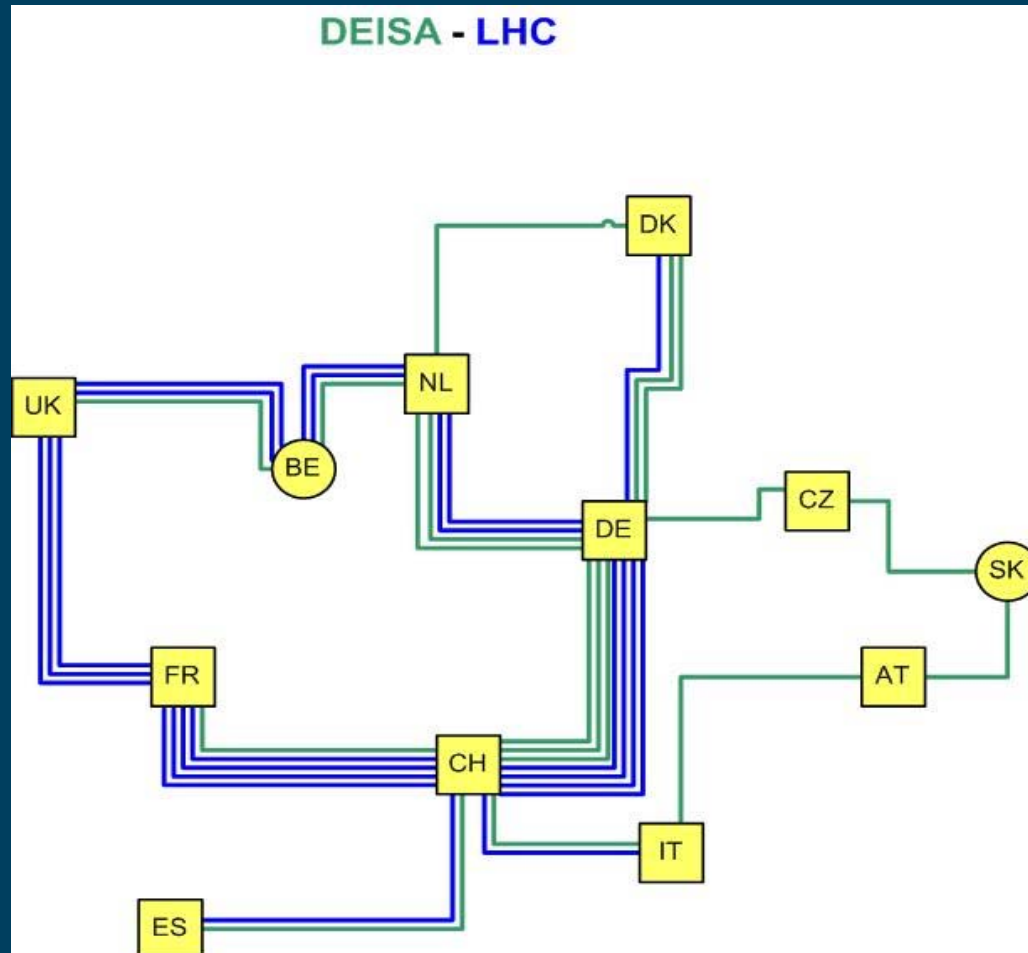

A view of the future: OPNs on GÉANT2 Backbone, *Hans Döbbling*, DANTE



Connect. Communicate. Collaborate

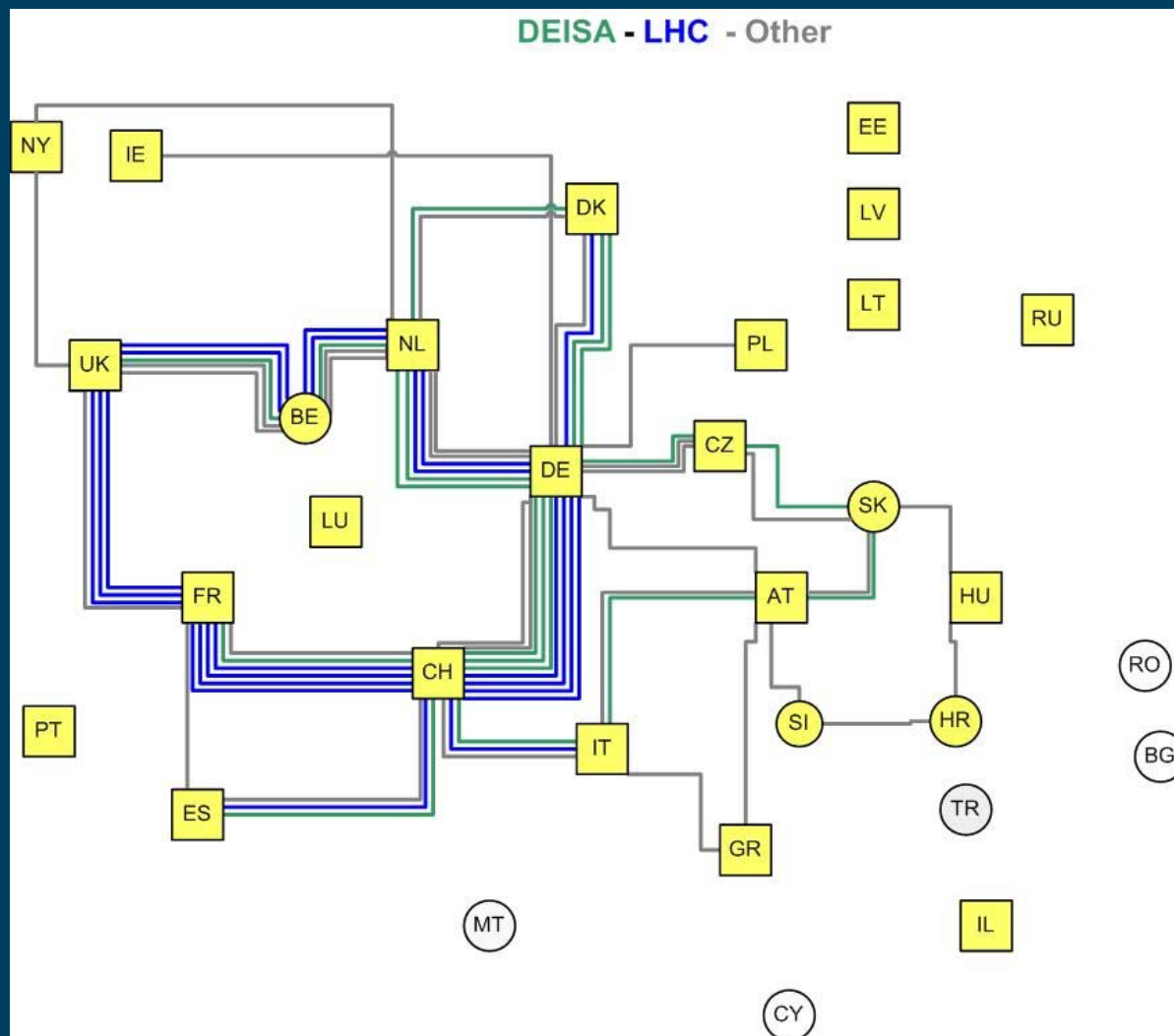

Challenges for NRENs - GÉANT as *e-Infrastructures*



Connect. Communicate. Collaborate

Business Model Issues

- *Long-term investment*, e.g. Dark Fiber leasing vs. IRUs ?
- From a hierarchical PS provision (aka. ISP tier1 → tier2) to a PS/CS Hybrid network with cross border fiber provisions: *Management, Control, Cost Sharing*
- Connecting to Open Exchanges (L1 – L3), *AUPs*
- Inclusion of schools, public libraries ... e-Government. Market competition & regulatory issues ? (*SERENATE study → Earnest*)
- Security & AAA harmonization – *legal issues towards a US of Europe !*
- *Governance* structure in Europe
 - NREN PC sets policy & forges unity of *34+ NRENs*
 - Executive Committee guides detailed project roll-out
 - Roles of DANTE & TERENA
- The US experience: Internet2 – NLR merger ?
- *Global connectivity* - services to end-users: Projects, individuals
- *e-Infrastructures* as an equalizer, reducing the **DIGITAL DIVIDES** in Europe & Globally: **Big Science affordable via Virtual e-Science**

Challenges for NRENs - GÉANT as *e-Infrastructures* (cont.)



Connect. Communicate. Collaborate

Multi-domain Hybrid Network Management & Control

- **Data**: 40 Gig, framing, granularity, multicasting ...
- Multi-domain Optical **Control**
 - Extending “BGP” to L1-L2 **routing** across domains
 - Ubiquitous **addressing** at protocol levels below L3, promise of **IPv6**
 - Integrate within Distributed Computing (Grid) middleware functionality
- Multi-domain **Management** - e2e Provisioning:
 - Scheduling, automated e2e set-up in near real-time
 - Coordination across domains with high-end user feedback
 - Coordination of *e-Infrastructure* Resource Allocation, Monitoring & Control: NRENs, GÉANT2, Distributed Computing Middleware – Grids, Supercomputing Centers
- Consolidate AAI (AAA) Architectures into federated schemes for global *e-Infrastructures*

Challenges for NRENs - GÉANT as e-Infrastructures (cont.)



Connect. Communicate. Collaborate

Virtualization at all levels

- Optical Private Networks (OPNs)
- L2, L3 VPNs (VLANs, VPLS, MPLS/TE)
- Application level Overlays (PlanetLab....)

- Virtualization enables co-existence of Production Quality Networks for Research & Testbeds for Research on Networks
- Strong interaction with industry on testbed deployment & experimentation – value adding by European researchers
- Coordination of European (Campus/NREN/GÉANT2) with Global Testbed activities (e.g. US NSF - GENI funded)

Choice of IPv6 for Addressing & Routing



Connect. Communicate. Collaborate

- Use IPv6 protocols & technologies for the **routed part of the NREN - GEANT backbones** (+ management of distributed storage & processing resources, Grids ?)
- Use IPv6 for **large IP overlays**, e.g. school nets, student home access (DSL)
- Use IPv6 advanced features for **end-user configuration** (DHCP+), **multicasting** & **roaming** user support (AAI, digital libraries, VPN provisioning....)
- Use IPv6 addresses for all Network Elements (?): **Ubiquitous, universal 128 bit** choice in a Hybrid Global Network

IPv6 @ a glance



Connect. Communicate. Collaborate

- **IPv6 Address:** 128 bits
 - GÉANT Address Space → **2001:798::/32**
- **Allows for routable addresses for “everything”**
 - IP phones, 3G devices, sensors, personal devices, appliances ...
- **Easy way of end-system configuration**
 - IP address auto-configuration: ***address_prefix:f(MAC_address)***
 - Enhanced DHCP parameter passing: NTP, SMTP, SIP ... servers (in addition to IP address, GW, DNS)
 - DHCP ***prefix delegation*** – assign multiple addresses to a client
- **Better support of mobility**
 - Multiple IPv6 addresses per interface, associated with multiple networks
- **Multi-homing potential**
- **Security**
 - Mandatory ***IPSec*** support (optional use)
 - Might open unknown network security hazards (new technology)
- **Multicasting:**
 - Specific multicast groups (e.g. all routers in an Ethernet LAN)
 - Embedded Rendezvous Points **selected at session initiation**
- **QoS** *Flow Label* in header allows easy packet differentiation (not in use yet)

IPv6 in Europe - GÉANT



Connect. Communicate. Collaborate

- **IPv6 deployment**
 - April 2003: First pilots, *Rediris* (SPAIN) and *Renater* (FRANCE)
 - May 2003: IPv6 connection to *Abilene* (USA)
 - June 2003: IPv6 connections to *SINET* (JAPAN)
 - July 2003: IPv6 Connection to *Canarie* (CANADA)
 - Commercial networks: *Telia* (May 2003), *Global Crossing* (July 2003)
 - October 2003: Operational support in GÉANT
 - January 2005: IPv6 Multicast
 - **June 2006: 53/41TBytes incoming / outgoing traffic**
- **Operational issues**
 - Similar policy (peering, AUPs) for IPv4 and IPv6 traffic
 - Similar service levels for IPv4 and IPv6
 - IPv6 traffic monitoring tools (packet filters, BGP session monitoring ...)
- **Network**
 - Dual stack (native IPv6) backbone network
 - Support of BGP and ISIS

GÉANT IPv6 Connectivity & Peering



Connect. Communicate. Collaborate

- **European NRENs**

- ACONET, ARNES, BELNET, CARNET, CERN, CESNET, CYNET, DFN, EENET, FCCN, GARR, GRNET, HEAnet, HUNGARNET, IUCC, ISTF, JANET, LITNET, NORDUnet, PSNC, RedIRIS, RENATER, RESTENA, RoEduNet, SANET, SURFnet, SWITCH, ULAKNET, University of Malta
- All but three connected via native IPv6 links

- **International**

- Abilene, CANARIE, ESnet, RedCLARA, TEIN2
- SINET, APAN-KR via *RENATER* (FRANCE)

- **Commercial:** Telia



NTUA – NATIONAL TECHNICAL
UNIVERSITY OF ATHENS





Connect. Communicate. Collaborate

GÉANT – NREN Traffic Statistics 2006

Access Ports	Speed Mbps	IPv6 Transmitted To GEANT2			IPv6 Received From GEANT2			Traffic Asymmetry	Max. Load
		Average Mbps	Peak Mbps	Volume Gbytes	Average Mbps	Peak Mbps	Volume Gbytes	See Appendix	See Appendix
GEANT2 Primary									
ACONET ↔ AT	10,000	0.04	0.90	12.15	0.02	2.00	6.74	0.29	0.00%
BELNET ↔ NL	10,000	36.61	49.99	11862.13	10.91	16.79	3534.35	0.54	0.37%
CESNET ↔ CZ	10,000	0.57	14.50	186.24	0.10	23.60	31.27	0.71	0.01%
CYNET ↔ GR	155								
DFN ↔ DE	10,000	0.37	23.70	120.30	0.09	21.99	27.93	0.62	0.00%
EENET ↔ EE	1,000								
FCCN ↔ PT	2,500	0.76	5.87	245.82	0.41	20.03	131.71	0.30	0.03%
GARR ↔ IT	10,000	0.02	4.14	6.19	0.05	20.43	16.56	-0.46	0.00%
GRNET ↔ GR	10,000	0.06	5.29	20.35	0.15	9.27	47.08	-0.40	0.00%
HEANET ↔ IE	2,500	8.17	27.37	2648.34	1.57	20.36	509.39	0.68	0.33%
HUNGARNET ↔ HU	10,000	0.02	1.81	5.09	0.04	13.36	13.71	-0.46	0.00%
ISTF ↔ HU	155	0.00	0.14	0.58	0.01	1.75	2.88	-0.66	0.01%
IUCC ↔ IL	620	0.00	0.00	0.00	0.00	0.00	0.03	-1.00	0.00%
JANET ↔ UK	10,000	0.02	1.02	5.18	0.06	3.51	18.63	-0.56	0.00%
JSCC ↔ DE	622								
LATNET ↔ DK	155								
LATNET ↔ LV	155								
LITNET ↔ LT	1,000	0.05	2.80	16.49	0.25	7.80	81.32	-0.66	0.03%
MALTA ↔ IT	20	0.00	0.25	0.16	0.01	6.06	2.17	-0.86	0.03%
NORDUNET ↔ DK	10,000	20.83	41.40	6749.63	42.04	50.00	13620.73	-0.34	0.42%
PSNC ↔ PL	10,000	4.82	9.68	1561.23	21.77	42.81	7053.38	-0.64	0.22%
REDIRIS ↔ ES	10,000	0.04	14.56	13.74	0.03	6.63	8.10	0.26	0.00%
RENATER ↔ FR	10,000	0.51	32.00	166.05	0.32	32.25	104.26	0.23	0.01%
RESTENA ↔ LU	1,000	0.01	1.59	2.01	0.04	39.06	12.64	-0.73	0.00%
ROEDUNET 1 ↔ HU	622	0.01	0.44	3.99	0.21	11.75	69.53	-0.89	0.03%
ROEDUNET 2 ↔ HU	622	0.01	0.44	3.99	0.21	11.75	69.53	-0.89	0.03%
SURFNET ↔ NL	10,000	42.91	50.00	13901.51	0.00	6.75	1.56	1.00	0.43%
SWITCH ↔ CH	10,000	45.12	49.99	14619.30	35.99	50.00	11659.79	0.11	0.45%
ULAKBIM ↔ GR	622	0.00	0.00	0.00	0.00	0.00	0.03	-1.00	0.00%



NTUA – NATIONAL TECHNICAL
UNIVERSITY OF ATHENS



GÉANT – NREN IPv6 Traffic History



Connect. Communicate. Collaborate

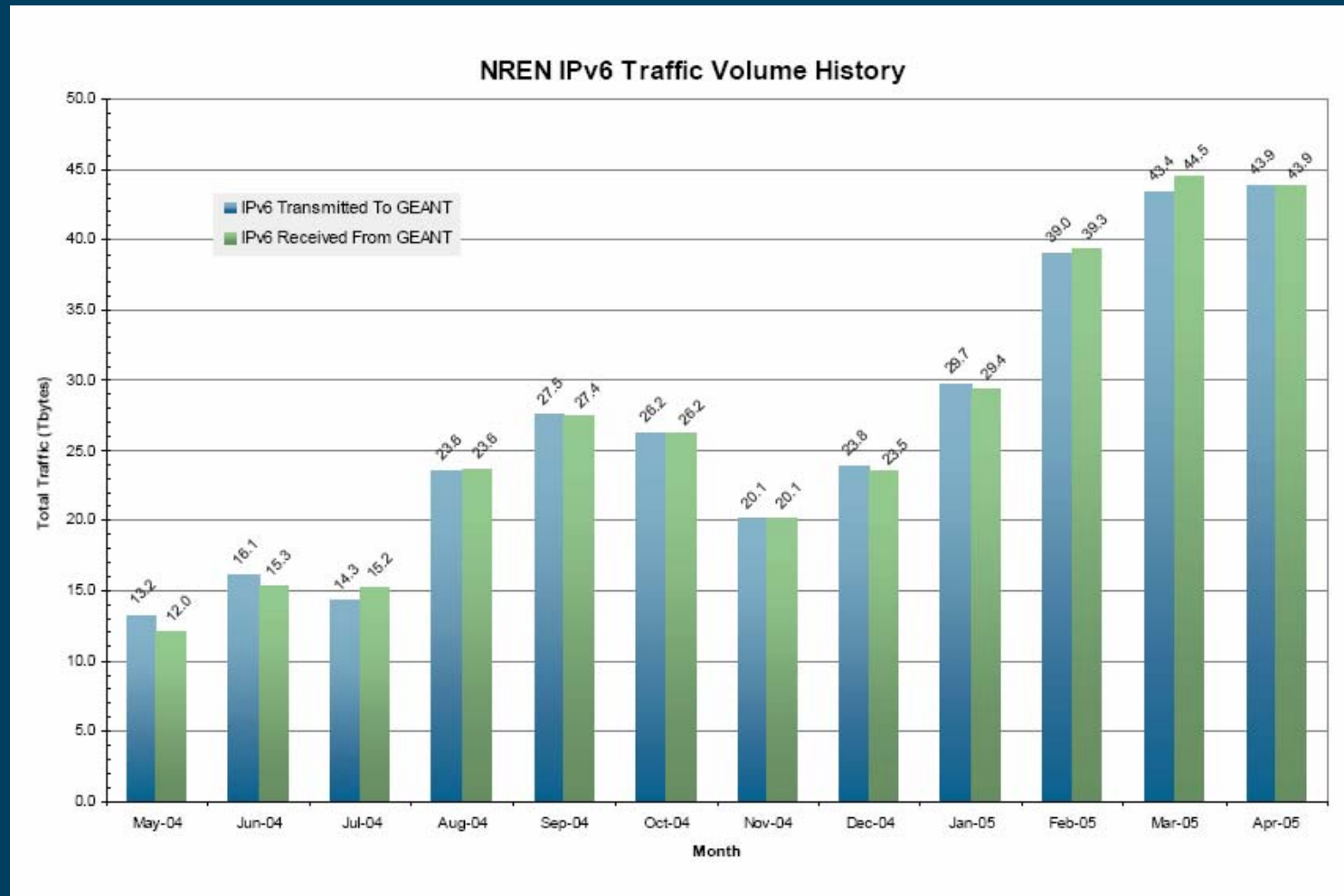

IPv6 vs IPv4 Traffic volume

**GÉANT v6 traffic volume:
2% IPv6 of the total traffic**



Connect. Communicate. Collaborate

IPv6 traffic statistics for SWITCH to/from GÉANT (April 2005)

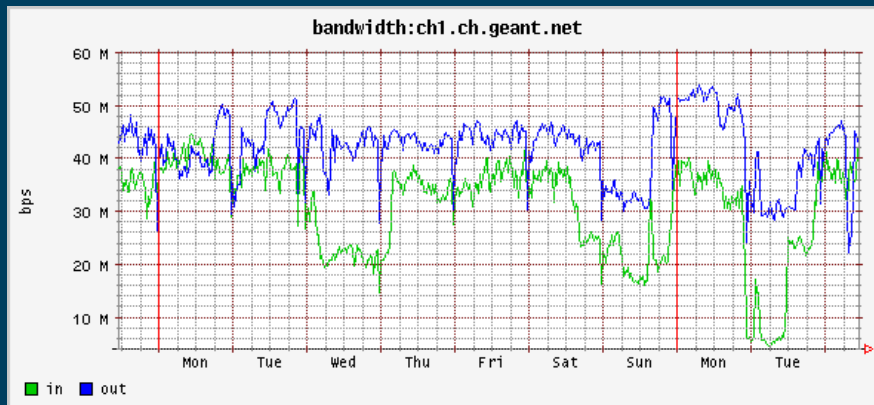

IPv6 daily traffic stats for SWITCH access to GÉANT

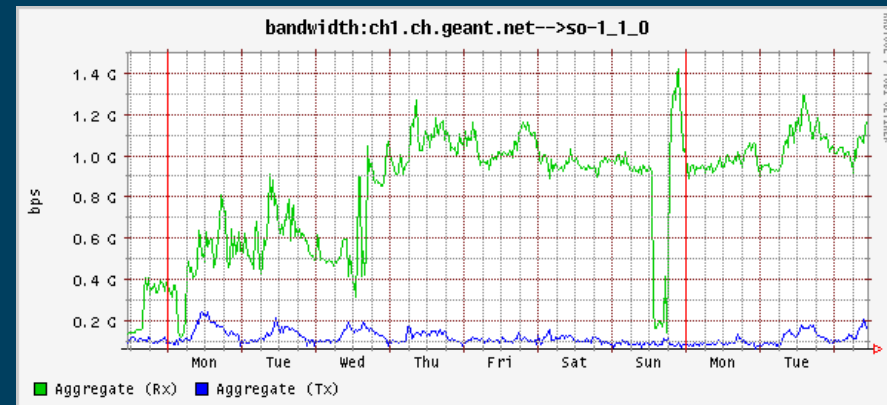

Daily total traffic stats for SWITCH access into GÉANT

IPv6 Multicast in GÉANT



Connect. Communicate. Collaborate

- **Native Multicast IPv6 across GÉANT backbone**
 - Pilot service ready since early 2005
 - Tested in 2004 in collaboration with Multicast v6 TF
 - Request for specific *mcast* v6 features from router vendors
- **Several NRENs connected to the multicast IPv6 enabled core**
 - 12 NRENs already connected - 7 in native, rest in tunnels
 - Connectivity to *M6bone* via *Renater* (FRANCE)
 - Native connectivity to *Abilene* (USA)

IPv6 NREN Experience: GRNET



Connect. Communicate. Collaborate

- **IPv6-only test network since 2002 – 6NET**
 - Connect Athens, Thessaloniki, Patra and Heraklion (Crete)
 - Validate protocols and routers functionality
- **GRNET dual stack IPv6 network**
 - GRNET2 since December 2003
 - Basic networking services, e.g. DNS, and monitoring
 - Gradual increase of IPv6 traffic towards GEANT, on average 50 GByte in 2006
- **IPv6 support in Universities**
 - 8 Universities active with *native IPv6* connections
 - Services: Address allocation, native connectivity, servers, multicast, etc
- **IPv6 deployment in Greek School Network**
 - Dual stack core network + ADSL/WiFi *native IPv6* access for 150 schools
 - Plan smooth migration IPv6



NTUA – NATIONAL TECHNICAL
UNIVERSITY OF ATHENS



IPv6 Plans for Related Regions



Connect. Communicate. Collaborate

- **SEEREN2** (*South Eastern Europe*)
 - IPv6 interconnection services achieved
 - Monitoring infrastructure deployed.
- **EumedConnect** (*Mediterranean Region, North Africa & Middle East*)
 - Plans for deployment
- **RedCLARA - ALICE** (*Latin America*)
- **SILK** (*Caucasus & Central Asia*)
 - IPv6 Streaming over Satellite

Conclusion



Connect. Communicate. Collaborate

- NRENs - GÉANT2 are leading edge **hybrid optical network infrastructures**
- **Global IPv6 coverage**: Accomplished in NRENs – GÉANT2, still small penetration to end users
- Major issues:
 - Multi-domain management & control of e2e circuit & packet switched services, integrated within distributed computing - Grid middleware
 - Deploy federated value added services (AAI, roaming, user support...)
 - Provision ubiquitous e2e/VPN services at Layers 1 (OPN), 2 (GigE), 3 (IPv6)
 - Enable advanced services to the Global Research & Education Community
 - Evolve sustainable business models & Governance structure
 - Expand electronic scientific & educational collaboration, virtualize *big science* → **Ease Digital Divides**